

# Nice

## BiDi-Switch

### Power switch bidirectional interface

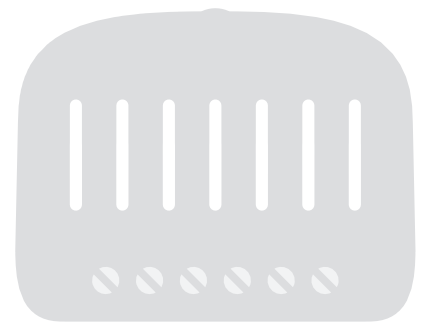

**EN** - Instructions and warnings for installation and use

**Nice**

## 1 WARNINGS AND GENERAL PRECAUTIONS

- **CAUTION! – This manual contains important instructions and warnings for personal safety.** Carefully read all parts of this manual. If in doubt, suspend installation immediately and contact the Nice Technical Assistance.
- **CAUTION! – Important instructions: keep this manual in a safe place to enable future product maintenance and disposal procedures.**
- **CAUTION! – All installation and connection operations must be performed exclusively by suitably qualified and skilled personnel with the unit disconnected from the mains power supply.**
- **CAUTION! – Any use other than that specified herein or in environmental conditions other than those stated in this manual is to be considered improper and is strictly forbidden!**
- This product may only be used indoors or protected from weather conditions by control unit's housing.
- The product's packaging materials must be disposed of in full compliance with local regulations.
- Do not open the device protection housing as it contains non-serviceable electrical circuits.
- Never apply modifications to any part of the device. Operations other than those specified may only cause malfunctions. The manufacturer declines all liability for damage caused by makeshift modifications to the product.
- Never place the device near to sources of heat and never expose to naked flames. These actions may damage the product and cause malfunctions.
- This product is not intended for use by people (including children) with reduced physical, sensory or mental capabilities or who lack experience and knowledge, unless they have been given supervision or instruction concerning the use of the product by a person responsible for their safety.
- Make sure that children do not play with the product.
- Check the warnings in the instruction manual for the device that the product is connected to.
- Handle the product with care, being sure not to crush, knock or drop it in order to avoid damage.

## 2 PRODUCT DESCRIPTION

The BiDi-Switch control unit makes it possible to switch on/off up to 2 mains-powered electric devices

The BiDi-Switch control unit incorporates a radio transceiver that operates at the frequency of 433.92 MHz with rolling code technology to guarantee optimal safety levels.

Each control unit can memorise up to 30 mono or bidirectional transmitters in the series ERA, ERGO, FLOR, NICEWAY and VERY, which enable the remote control of the unit.

Two keys are used on each transmitter: one for toggle command for first output and one for toggle command for second output. The control unit memorizes the ON-OFF status of the connected devices, so in the event of a power failure, when the power supply is restored the output returns to the previous status.

The control unit is equipped with two inputs for controlling the two outputs by means of external push-buttons.

Memorisation and programming is possible via the programming pushbutton (figure 1) on the BiDi-Switch.

The user is guided through the various phases by means of LED signals.

The control unit is equipped with overload, and overheating protection, which will disable the relays to prevent damage to the circuit.

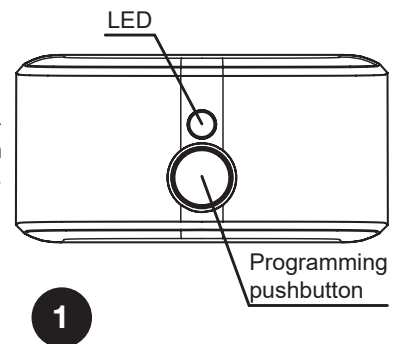

## 3 INSTALLATION



- **The product is subject to hazardous electric voltages**
- **The installation of the BiDi-Switch and automations must be performed exclusively by technically qualified personnel, in observance of current legislation and standards, and according to these instructions. All connections must be made with the system disconnected from the power supply.**
- **The BiDi-Switch control unit has been especially designed for insertion in a junction box or wall box; its housing does not feature any protection against water and only basic protection against contact with solid parts. Never place the BiDi-Switch in inadequately protected environments.**
- **Never open or perforate the BiDi-Switch housing, this is subject to hazardous electric voltages!**

### 3.1 - Preliminary checks

- The power supply line must be protected by suitable magneto-thermal (compliant with IEC/EN 60898-1 standard, rated up to 16A) and residual-current circuit breakers.
- A disconnection device must be inserted in the power supply line from the electrical mains (the distance between the contacts must be at least 3mm with an overvoltage category of III) or equivalent system, for example an outlet and relative plug. If the disconnection device for the power supply is not mounted near the automation, it must have a locking system to prevent unintentional, unauthorized connection

### 3.2 - Electrical connections

**⚠ ⚠** Carefully follow all the connection instructions. If you have any doubts do not make experiments but consult the relevant technical specifications which are also available on the web site: [www.niceforyou.com](http://www.niceforyou.com). An incorrect connection may be dangerous and cause damage to the system.

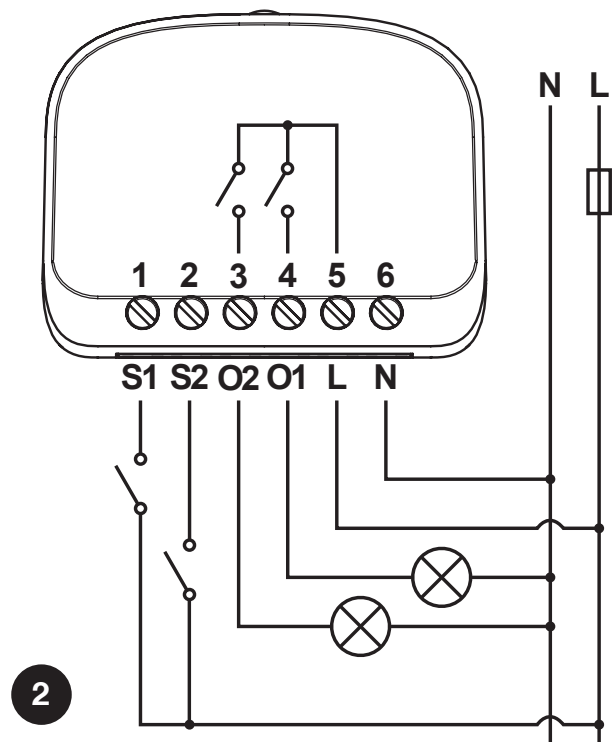

### 3.3 - Electrical connection of the device

The first device to be controlled must be connected between neutral (N) and terminal O1; the second device must be connected between neutral (N) and terminal O2 of the control unit; the devices is powered directly by the control unit.

### 3.4 - Power supply

The electric power supply of the control unit must be connected by means of terminals L and N (Live, Neutral). The BiDi-Switch control unit can operate with supply voltage of 100 to 240 Volts and frequency of 50 or 60 Hz.

### 3.5 - Switches

If required, external switches can be connected to terminals S1 and S2, which can control the outputs directly. The switches are connected between Live (L) and terminals S1 and S2 as shown in figure 2. The switch connected to S1 is responsible for O1 control, and the switch connected to S2 is responsible for O2. Toggle or momentary switches can be connected to S1 and S2 terminals, but the operation of the control unit might need to be adjusted for the connected type of switch, to check and change the type of switch see table A10.

**⚠ ⚠** The switches carry mains voltage and must therefore be adequately protected and insulated.

## 4 MEMORISING TRANSMITTERS

- This chapter describes the memorisation procedures in Mode I, used to control a single automation with the 2 keys of the transmitters and Mode II, used to control an automation with a single key, thus leaving the other keys free for control of other automations.
- The key ■ corresponds to the central key of the transmitters ERGO, PLANO and NICEWAY.
- All memorisation sequences are timed, which means they must be completed within the set time limits.
- With transmitters that envisage several “groups”, the relative group to associate with the control unit must be selected before proceeding.
- Settings via radio are possible on all receivers located within the operating radius of the transmitter, and therefore only the device required for the operation should remain powered.





## 4.1 - Mode I

In Mode I the command associated with the transmitter keys is fixed (table A1). In Mode I only one memorisation phase is performed for each transmitter and only one memory location is occupied. During memorisation in Mode I it is not important which key is pressed on the transmitter.

Table A1 - Memorisation using Mode I	
Key	Command
Key ▲ or 1st channel	Toggle output 1
Key ■ or 2nd channel	Toggle output 2
Key ▼ or 3rd channel	–
4th channel	–





## 4.2 - Memorising transmitters in Mode I

When there is no transmitter memorised, the first can be memorised during startup according to the following procedure.





Table A2 - Memorising first transmitter during startup in Mode I		Example
01.	Connect the control unit to the power mains, confirmed by 2 red flashes.	
02.	Within 10 seconds: <ul style="list-style-type: none"> <li><b>Monodirectional transmitters:</b> press and hold and key of the transmitter to be memorized for at least 3 seconds.</li> <li><b>Bidirectional transmitters:</b> press any key of the transmitter to be memorized</li> </ul>	MONO:  BIDI: 
03.	If the memorisation procedure is successful, the LED emits 3 red flashes.	

If no transmitters should be memorized during startup, the programming procedure concludes automatically after 10 seconds and the LED emits one long red flash.

The transmitters can be memorised using the programming pushbutton according to the following procedure.

Table A3 - Memorising first and other transmitters in Mode I		Example
01.	Press and hold the programming pushbutton (fig. 1).	
02.	Release the programming pushbutton (fig. 1) when the LED illuminates with <b>red</b> color (1st position).	
03.	Within 10 seconds: <ul style="list-style-type: none"> <li><b>Monodirectional transmitters:</b> press and hold and key of the transmitter to be memorized for at least 3 seconds.</li> <li><b>Bidirectional transmitters:</b> press any key of the transmitter to be memorized</li> </ul>	MONO:  BIDI: 
04.	If the memorisation procedure is successful, the LED emits 3 red flashes.	
05.	Repeat steps 3 and 4 to acquire all the remotes.	
06.	After 10 seconds that the device doesn't receive any signal, the programming procedure concludes automatically.	

If transmitters have already been memorised, other transmitters can be memorised as described in the following procedure.

Table A4 - Memorising other transmitters with a previously memorised transmitter in Mode I		Example
01.	Press any key three times of a <b>previous</b> , memorised transmitter.	Old  x3
02.	Press the same key three times of a <b>new</b> transmitter.	New  x3
03.	Press the same key three times of a <b>previous</b> , memorised transmitter.	Old  x3
04.	Press the same key of the <b>new</b> transmitter.	New 
05.	If the memorisation procedure is successful, the LED emits 3 red flashes.	
06.	The programming procedure concludes automatically.	







**Note.** If the memory is full (30 transmitters memorised) 6 red flashes are emitted and the transmitter cannot be memorised.

### 4.3 - Mode II

In Mode II each key of the transmitter can be associated with one of 6 possible commands (table A5); for example, one automation can be controlled with just one key memorised for the Toggle output 1 command, while the other keys are left free for control of other automations. In Mode II one memorisation phase is performed for each key and each occupies one location in the memory. During Mode II memorisation, the specific key pressed is memorised. If another key is to be assigned a command on the same transmitter, a new memorisation phase must be performed for that specific key.

Table A5 - Memorisation using Mode II	
N°	Command
1	ON output 1
2	OFF output 1
3	Toggle output 1
4	ON output 2
5	OFF output 2
6	Toggle output 2

### 4.4 - Memorising transmitters in Mode II





Table A6 - Memorising first and other transmitters in Mode II		Example
01.	Press and hold the programming pushbutton (fig. 1).	
02.	Release the programming pushbutton (fig. 1) when the LED illuminates with <b>orange</b> color (2nd position).	
03.	Press the programming pushbutton (fig. 1) the number of times corresponding to the required command (1 = ON output 1, 2 = OFF output 1, 3 = toggle output 1, 4 = ON output 2, 5 = OFF output 2, 6 = toggle output 2).	1-6 
04.	Check that the LED emits the number of long orange flashes corresponding to the required command.	1-6 
05.	Within 10 seconds: <ul style="list-style-type: none"> <li><b>Monodirectional transmitters:</b> press and hold the required key of the transmitter to be memorized for at least 3 seconds.</li> <li><b>Bidirectional transmitters:</b> press the required key of the transmitter to be memorized</li> </ul>	MONO:  BIDI: 
06.	If the memorisation procedure is successful, the LED emits 3 orange flashes.	
07.	Repeat steps 5 and 6 to acquire all the remotes with the same command.	
08.	Repeat steps 3 to 6 to acquire all the remotes with another command.	
09.	After 10 seconds that the device doesn't receive any signal, the programming procedure concludes automatically.	

**Note.** If the memory is full (30 transmitters memorised) 6 orange flashes are emitted and the transmitter cannot be memorised.

### 4.5 - Memorising a new transmitter using the “enabling code” of an already memorised transmitter

The bidirectional transmitter has a secret code, the so-called “enabling code”. By transferring this code from a memorized transmitter to a new transmitter, the latter is recognized (and memorized) automatically by the control unit. Please refer to the manual of the transmitters for further details.

**Warning! - The enabling code can only be transferred between two transmitters that have the same radio coding.**

Table A7 - Transmitting the “enabling code”		Example
01.	Bring a <b>previous</b> , memorised transmitter and the <b>new</b> transmitter close to one another.	
02.	On the <b>new</b> transmitter press command key. The LED of the <b>previous</b> transmitter will switch on and start flashing.	New  Old 
03.	On the <b>previous</b> transmitter press command key.	Old 
04.	Once the code has been transferred, for an instant both the transmitters will vibrate and the green LED will light up signalling end of the procedure. When the <b>new</b> transmitter will be used, for the first 20 times it will transmit this “enabling code” to the receiver together with the command. The receiver will automatically memorize the identification code of the transmitter that transmitted it	

## 5.1 - Auto Off

This function allows to automatically turn OFF the connected device when saved time passes from turning ON. By default, the auto OFF function for both outputs is disabled.

To set auto OFF time or disable the function, proceed as described below.

















Table A8 - Setting auto OFF for output 1		Example
01.	Press and hold the programming pushbutton (fig. 1).	
02.	Release the programming pushbutton (fig. 1) when the LED illuminates with <b>green</b> color (3rd position).	
03.	If you want to disable the auto OFF function, wait 10 seconds, so the programming procedure concludes automatically.	
04.	Press key of the transmitter for responsible turning ON the first output or S1 switch to start the timer.	 > START 
05.	Press key of the transmitter for responsible turning OFF the first output or S1 switch to stop the timer. The maximum time that can be set is 18 hours.	 > STOP 
06.	The auto OFF time is saved and the programming procedure concludes automatically.	

Table A9 - Setting auto OFF for output 2		Example
01.	Press and hold the programming pushbutton (fig. 1).	
02.	Release the programming pushbutton (fig. 1) when the LED illuminates with <b>white</b> color (4th position).	
03.	If you want to disable the auto OFF function, wait 10 seconds, so the programming procedure concludes automatically.	
04.	Press key of the transmitter responsible for turning ON the second output or S2 switch to start the timer.	 > START 
05.	Press key of the transmitter responsible for turning OFF the second output or S2 switch to stop the timer. The maximum time that can be set is 18 hours.	 > STOP 
06.	The auto OFF time is saved and the programming procedure concludes automatically.	

## 5.2 - Type of connected switches



The control unit allows to connect momentary or toggle switches to S1 and S2 input. By default, the toggle switch type is set.

To change type of connected switch, proceed as described below.

Table A10 - Setting type of connected switches		Example
01.	Press and hold the programming pushbutton (fig. 1).	
02.	Release the programming pushbutton (fig. 1) when the LED illuminates with <b>violet</b> color (5th position).	
03.	Press key of the transmitter responsible for turning ON any output to toggle the setting, the LED informs about current setting: <ul style="list-style-type: none"> <li>• Fixed violet – momentary switch</li> <li>• Turned off – toggle switch</li> </ul>	 >  / 
04.	After 10 seconds that the device doesn't receive any signal, the programming procedure concludes automatically.	

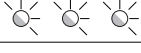

## 5.3 - Deleting transmitters

If memorised transmitters and settings need to be deleted, proceed as described below.

Table A11 - Deleting transmitter from memory		Example
01.	Press and hold the programming pushbutton (fig. 1).	
02.	Release the programming pushbutton (fig. 1) when the LED illuminates with <b>yellow</b> color (6th position).	
03.	Press any key on the acquired transmitter to remove it from memory.	
04.	LED emits 3 yellow flashes to confirm the correct removal.	
05.	After 10 seconds that the device doesn't receive any signal, the programming procedure concludes automatically.	

## 5.4 - Factory reset

If the control unit needs to be reset to the factory settings (all transmitters and setting will be deleted), proceed as described below.

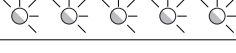
Table A12 - Restoring to factory defaults		Example
01.	Press and hold the programming pushbutton (fig. 1).	
02.	Release the programming pushbutton (fig. 1) when the LED illuminates with <b>yellow</b> color (6th position).	
03.	Press the programming pushbutton (fig. 1).	
04.	LED emits 5 yellow flashes to confirm the correct reset.	
05.	The programming procedure concludes automatically. Afterwards the control unit will initiate the start-up procedure according to table A2.	

## 6 LED SIGNALS

### 6.1 - Programming menu

When pressing and holding the programming pushbutton on the control unit, the LED will signal consecutive positions of the programming menu.

Table A13 - menu positions when holding the programming pushbutton		
N°	Color	Description
1	Red	Memorization in Mode I
2	Orange	Memorization in Mode II
3	Green	Auto OFF for output 1 settings
4	White	Auto OFF for output 2 settings
5	Violet	Switch type settings
6	Yellow	Reset

### 6.2 - Other signals

Table A14 - other LED signals	
Color	Description
2 red flashes	Control unit initialized properly
3 red flashes	Transmitter memorized in Mode I
3 orange flashes	Transmitter memorized in Mode II
6 red flashes	Memory for transmitters full (Mode I)
6 orange flashes	Memory for transmitters full (Mode II)
3 yellow flashes	Transmitter deleted from memory
5 yellow flashes	Control unit restored to factory settings

## 7 TECHNICAL SPECIFICATIONS

The product BiDi-Switch is produced by Nice S.p.a. (TV). Warnings: - All technical specifications stated in this section refer to an ambient temperature of 20 °C (± 5 °C) - Nice S.p.a. reserves the right to apply modifications to the product at any time when deemed necessary, while maintaining the same functionalities and intended use.

BiDi-Switch	
Type	in-wall/flush box mounted control unit for mains powered devices
Power supply	100–240 V AC, 50/60 Hz
Load rated current	6.5 A per channel, 10 A combined
Recommended wires cross-section	0.5–4 mm <sup>2</sup> for 1 wire; 0.5–1.5 mm <sup>2</sup> for 2 wires
Required circuit breaker	Compliant with IEC/EN 60898-1; Curve code: B; Rated current: up to 16 A; Breaking capacity: 6 kA; Rated insulation voltage: 500 V; Rated impulse withstand voltage: 4 kV;
Casing protection rating	IP 20
Operating temperature	0–35 °C
Dimensions (mm)	45 x 36 x h 23
Weight	20 g

Radio transceiver	
Frequency band	433.05–434.04 MHz
Code	OPERA/FLOR (rolling code), PLN2+ (rolling code)
No. of memorisable transmitters	30
Transceiver range	Estimated at 150 m in open space and 20 m inside buildings (*)
Max. transmit power	10 dBm

(\*) The transceiver range is strongly influenced by other devices operating at the same frequency with continuous transmission, such as alarms and radio headphones which interfere with the control unit transceiver.

## 7 PRODUCT DISPOSAL

This product is an integral part of the automation and therefore must be disposed together with the latter.

As in installation, also at the end of product lifetime, the disassembly and scrapping operations must be performed by qualified personnel. This product is made of various types of material, some of which can be recycled while others must be scrapped. Seek information on the recycling and disposal systems envisaged by the local regulations in your area for this product category.

**Caution!** – some parts of the product may contain pollutant or hazardous substances which, if disposed of into the environment, may cause serious damage to the environment or physical health.

As indicated by the symbol alongside, disposal of this product in domestic waste is strictly prohibited. Separate the waste into categories for disposal, according to the methods envisaged by current legislation in your area, or return the product to the retailer when purchasing a new version.

**Caution!** – local legislation may envisage serious fines in the event of abusive disposal of this product.



## 8 DECLARATION OF CONFORMITY

Hereby, NICE S.p.A., declares that the radio equipment type BiDi-Switch is in compliance with Directive 2014/53/EU.

The full text of the EU declaration of conformity is available at the following internet address: <http://www.niceforyou.com/en/support>





**Nice SpA**  
Oderzo TV Italia  
info@niceforyou.com

[www.niceforyou.com](http://www.niceforyou.com)